

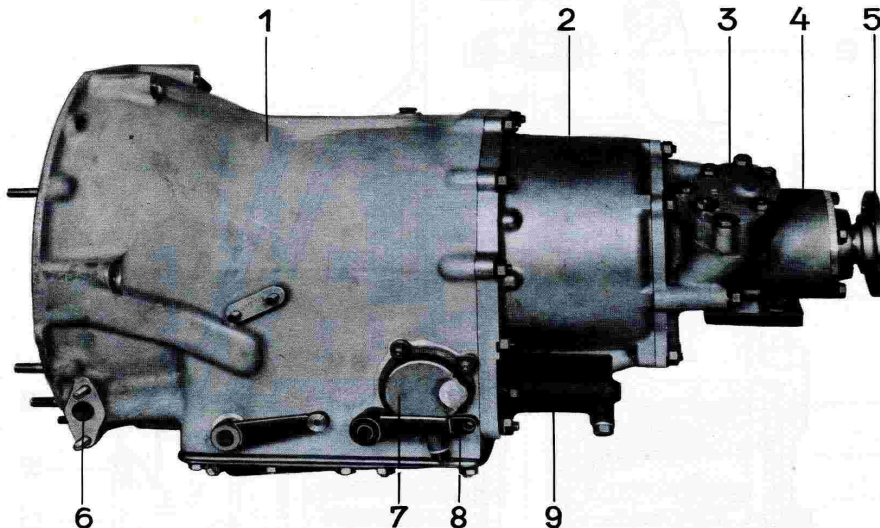

**Borgward-Hansamatic
Automatic Gearbox
Dismantling 36050
Assembling 36060**



- 1. Front case.
- 2. Centre case.
- 3. Rear pump.
- 4. Rear case.
- 5. Output flange.

- 6. Oil filler pipe flange.
- 7. 3rd gear capacity cylinder.
- 8. Gear box selector lever.
- 9. 2nd gear capacity cylinder.

Contents

	Pages.
Dismantling the gearbox	4 - 6
Assembling the gearbox	7 - 12
Dismantling the planetary gear train	13 - 14
Assembling the planetary gear train	15 - 18
Dismantling the brake unit	18
Assembling the brake unit	18 - 21
Dismantling hydraulic unit and front pump	21 - 22
Assembling hydraulic unit and front pump	22 - 23
Dismantling clutch unit	24
Assembling clutch unit	24 - 26
Dismantling front case assembly	26 - 27
Assembling front case assembly	27 - 28
Removal and fitting of speedometer drive gear	28
Dismounting gearbox and clutch from engine	28 - 29
Mounting clutch and gearbox on engine	29
Checking capacity cylinder pressures	30
Exploded view of hydraulic unit	31
BORGWARD - special tools	31
Useful tools and instruments	31
Homemade tools	32

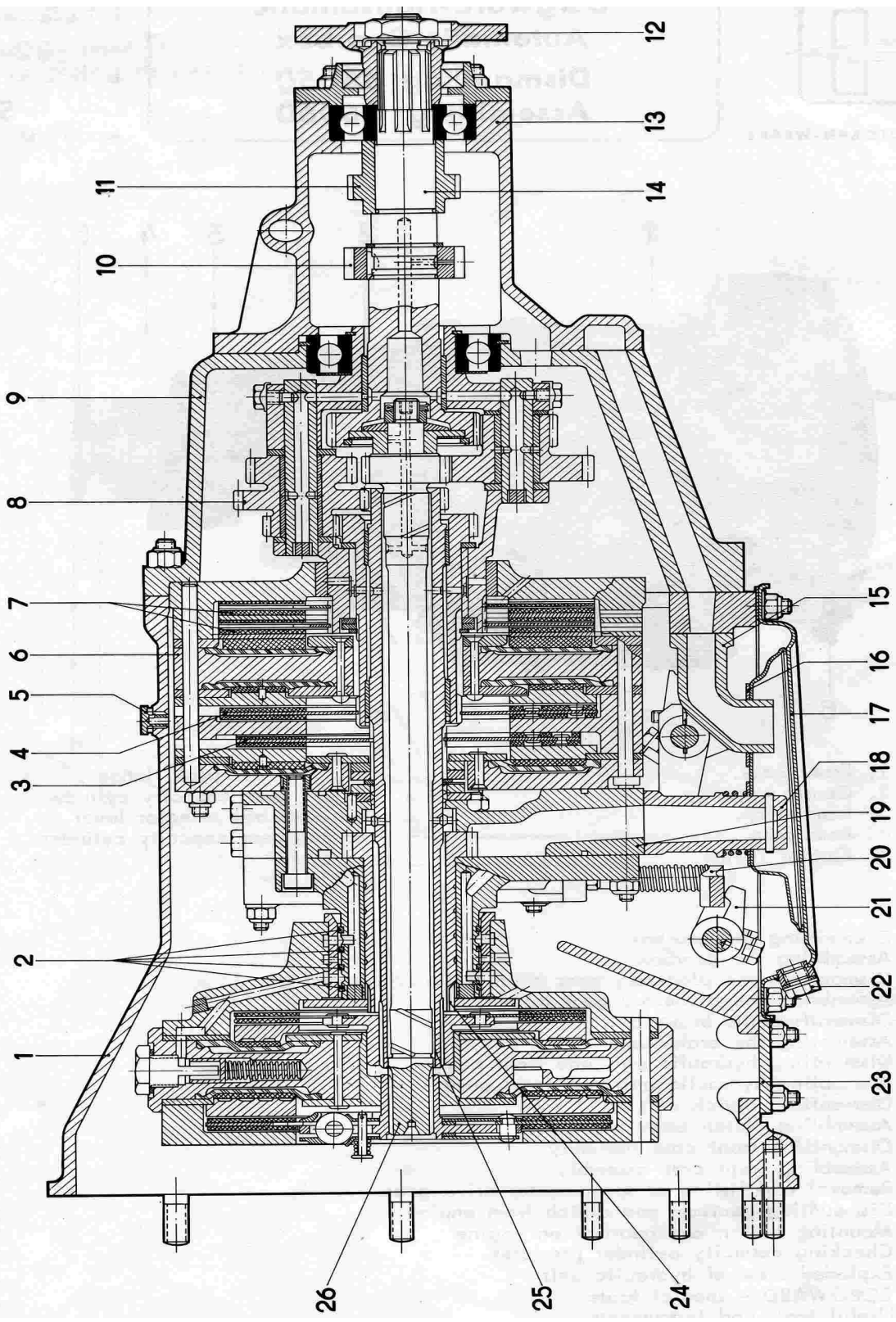

- | | |
|------------------------------|-----------------------------|
| 1. Front case | 14. Output shaft |
| 2. Clutch feed sealing rings | 15. Rear pump suction pipe |
| 3. 3rd gear spinner plate | 16. Oil filter sealing ring |
| 4. 2nd gear spinner plate | 17. Sump |
| 5. Breather | 18. Front pump suction pipe |
| 6. Brake diaphragm body | 19. Hydraulic unit |
| 7. 1st gear spinner plates | 20. Kickdown beam |
| 8. Planetary gears | 21. Actuating cam |
| 9. Centre case | 22. Drain plug |
| 10. Rear pump driving gear | 23. Clutch inspection cover |
| 11. Speedometer driving gear | 24. Front pump drive gear |
| 12. Output flange | 25. "B" Clutch input sleeve |
| 13. Rear case | 26. "A" Clutch input shaft. |

Dismantling the gearbox.

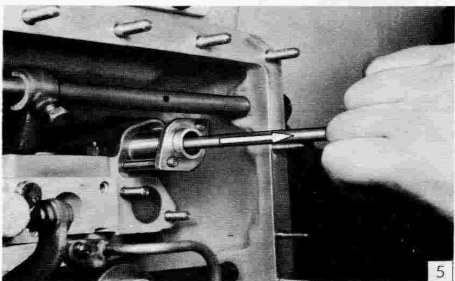
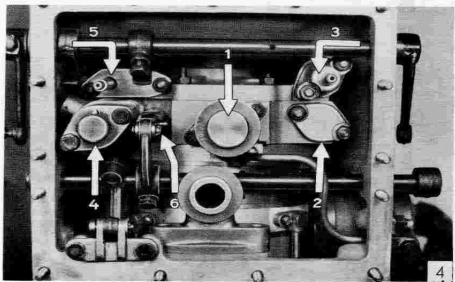
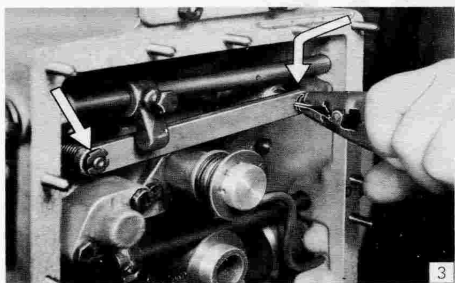
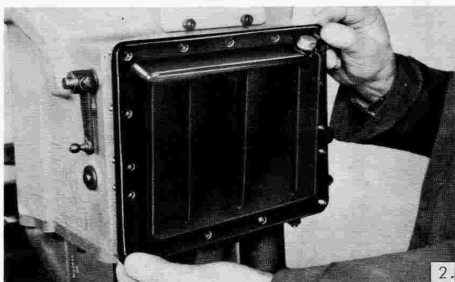
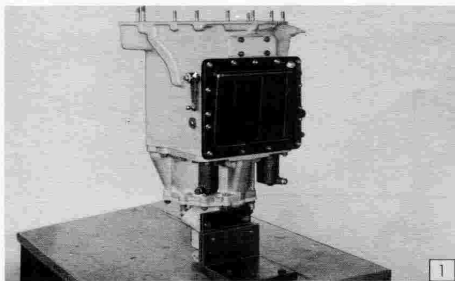

1. Bolt gearbox rear mounting to angle plate (fig. 1).
2. Remove sump, sump stiffener, and gasket (fig. 2).
3. Take out filter.
4. Detach twickclips (fig. 3) and take out beam and kickdown return spring.
5. Remove front pump suction pipe (fig. 4,1).
6. Dismantle brake relief valve (fig. 4,2). Unscrew nuts, lift off cover and take out spring and piston, with long nosed pliers, take out valve pin. Screw special tool into valve above bronze sleeve, and withdraw valve and sleeve.
7. Dismantle clutch relief valve (fig. 4,3), unscrew nuts, lift off cap together with regulator, spring guide pin, and springs. Screw special tool into valve above bronze sleeve and withdraw valve and sleeve (fig. 5).
8. Remove governor valve (fig. 4,4), unscrew bolts and take off cap, springs and guide pin, withdraw valve together with detent housing.
9. Take out kickdown and tow start valves (fig. 4,5), unscrew nuts, take off cap, gasket and tow start spring, withdraw both valves.
10. Remove detent pawl assembly, spring and plunger (note whether spacing washers have been fitted between detent pawl flange and casing).
11. Detach clip from retaining pin, push out pin and withdraw selector valve (fig. 4,6).

12. Take off 1st, 2nd and 3rd gear capacity cylinders, gaskets, and "O" rings (fig. 6).

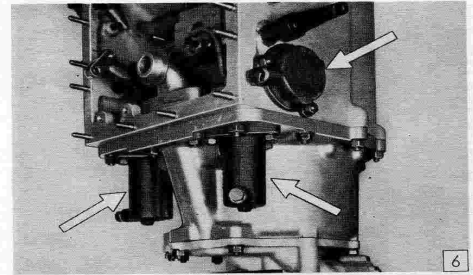

13. Remove capacity feed pipes (fig. 7).

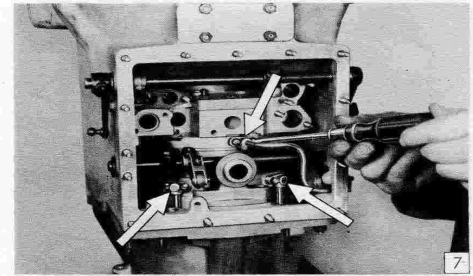

14. Unscrew nuts securing front case and lift case clear of unit (fig. 8).

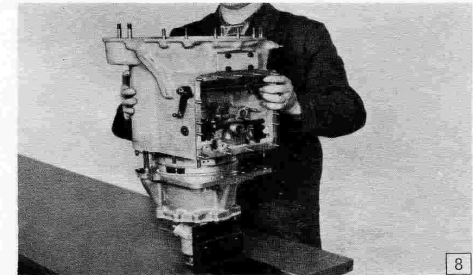

15. Unscrew nuts and allen screws securing hydraulic unit, gentle tapping at the rear pump delivery pipe flange will loosen hydraulic unit which may then be lifted off (fig. 9).

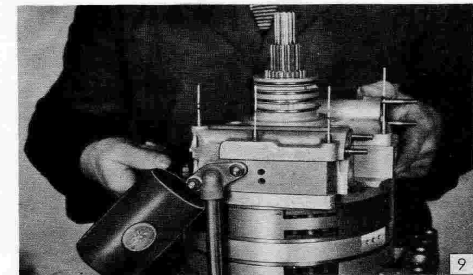

16. Lift out thrust washer (fig. 10) and remove circlip.

17. To remove the brake unit, unscrew the nut arrowed in (fig. 10) and lift off brake unit together with two remaining thrust washers, which may then be easily removed.

18. The gearbox is dismantled from the angle plate and the input shaft held in a soft jawed vice (fig. 16).

NOTE: The input sleeve must be clear of the vice, and it is most important that the vice be fitted with soft jaws to protect the input shaft splines.

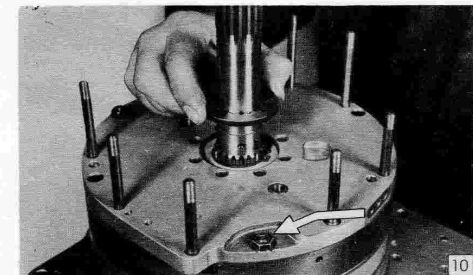

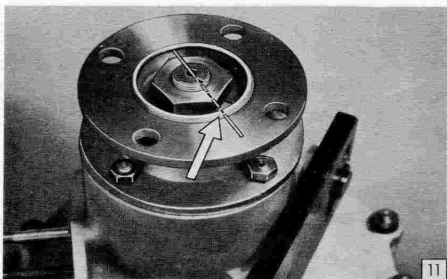

19. The output flange should be marked before withdrawing the flange (fig. 11).

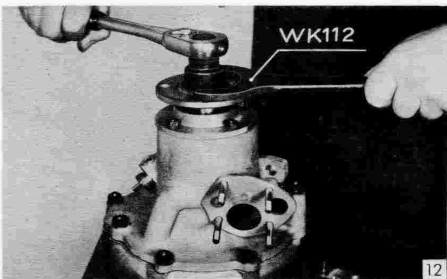

20. Bend tab washer away from nut and remove nut (fig. 12).

(Use "C" Spanner - WK 112)



21. Draw off flange using extractor WK 56 (fig. 13).

22. Unscrew four nuts securing oil seal housing and lift off housing.

23. Remove nuts retaining rear oil pump and withdraw pump (fig. 20).

24. Unscrew nuts securing centre and rear cases, gentle tapping with rubber mallet on rear mounting will loosen rear case (fig. 14).

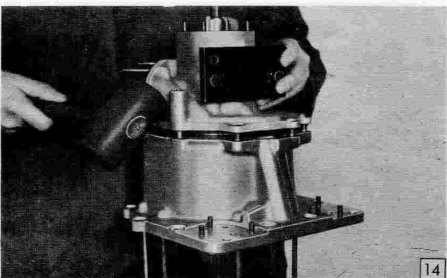

25. Remove speedometer driving gear.

26. The circlip fitted to the bearing outer race may be removed with the aid of circlip pliers and screwdriver.

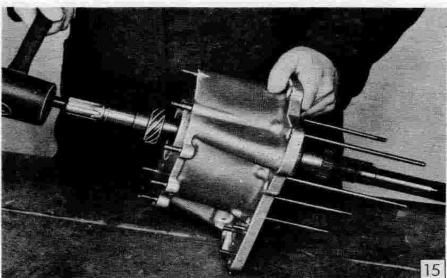

27. The unit is removed from the vice and the gear train driven out of the centre case with a rubber mallet (fig. 15).

28. Wash all components in petrol and blow off with compressed air.

Assembling the gearbox.

1. The gear train input shaft is held in a soft jawed vice.

NOTE: The input sleeve must be clear of the vice, and it is most important the vice be fitted with soft jaws to protect the input shaft splines (fig. 16).

2. The centre case is lowered over the output shaft and tapped with a rubber mallet until the circlip groove in the bearing outer race is fully exposed, the circlip is then fitted (fig. 17).

3. Fit a new gasket to the centre case, checking that oil feed holes are not sealed off.

4. Place the speedometer driving gear in position on the output shaft, with the long "spacer section" uppermost.

5. The rear case is lowered over the output shaft and secured with nuts and spring washers (fig. 18).

6. Drive the output shaft bearing fully home (fig. 19).

7. Fit the oilseal housing and new gasket, see that the drain slots in the gasket and housing are in line with the drain hole in the rear case.

8. The output flange is fitted with the markings on the flange and shaft in line, tighten nut and bend over tab washer.

9. Fit rear oil pump and new gasket (fig. 20), secure with nuts and spring washers.

10. Remove unit from vice and bolt rear mounting to angle plate.

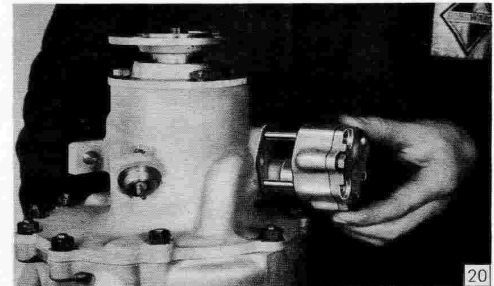
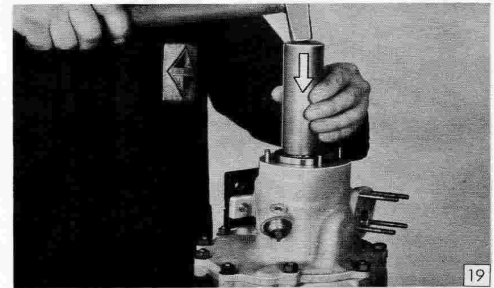
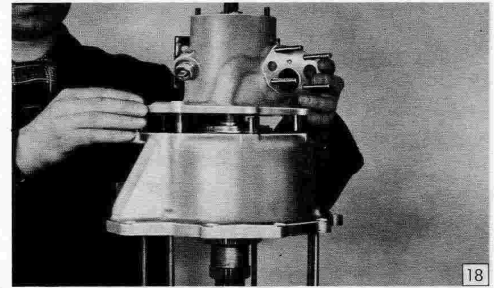
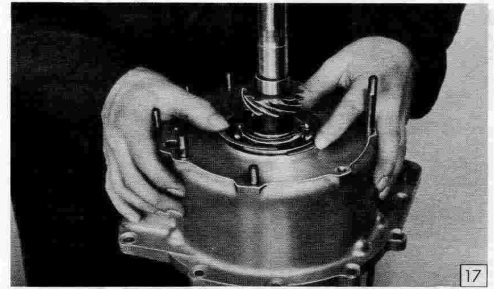
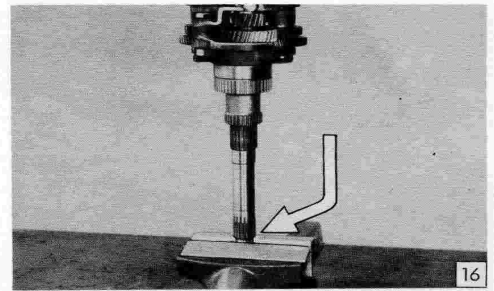

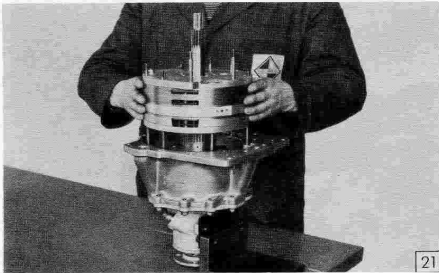

11. Smear the bronze bush in the brake back plate with oil, and lower the brake unit into position (fig. 21). If the operator supports the weight of the brake unit, and rotates the input shaft and sleeve, the brake spinner plates will engage with their appropriate splines.

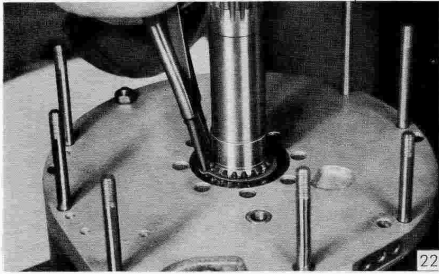

12. a) Fit bronze thrust washer.
 b) Fit steel thrust washer.
 c) Fit circlip in groove (fig. 22).
 d) Fit steel thrust washer.

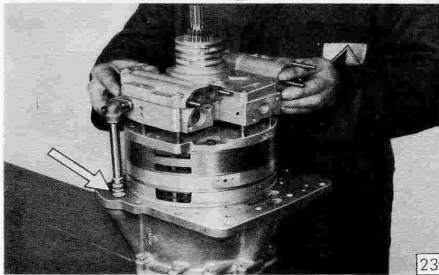

13. Remove finger marks from brake front plate with clean wash leather, do not use any fluffy material.

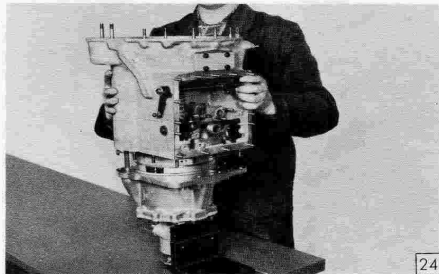

14. Wipe face of hydraulic unit with wash leather and lower on to brake front plate (fig. 23), the rear pump securing nuts are slacked off to allow pipe to position itself. The rubber "O" ring arrowed in fig. 23 should be renewed.

15. Secure hydraulic unit with allen screws, nuts and waved washers, tighten rear pump delivery pipe nuts.

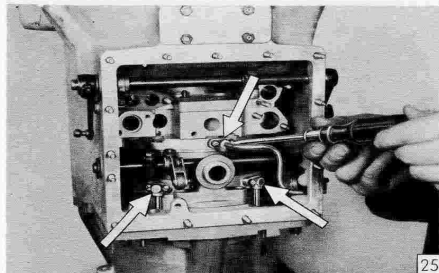

16. Fit a new "grease smeared" gasket to the front case and lower into position, secure with nuts and spring washers (fig. 24).

17. Fit capacity cylinder pipes using new gaskets (fig. 25).

18. Place new "O" ring in position in third gear capacity cylinder as arrowed in fig. 26, fit new gasket and secure with nuts and spring washers.

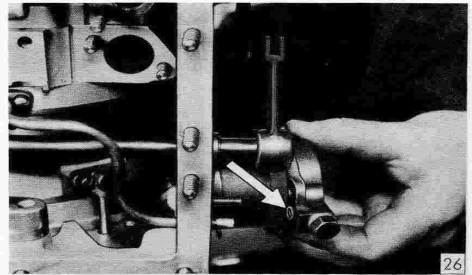

19. Fit new "O" rings to the first and second gear capacity cylinders and secure in position using new gaskets (fig. 27), the centre case flange and the capacity cylinders are stamped:-

E - First gear capacity cylinder
D - Second gear capacity cylinder

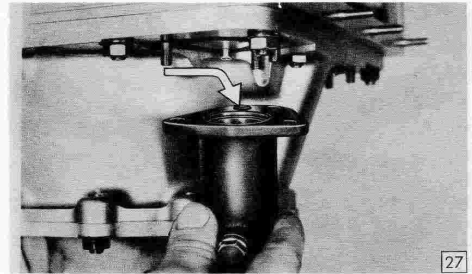

20. The selector valve is positioned with the "flat" uppermost (fig. 28), the pin inserted from the left as indicated and secured with "C" clip.

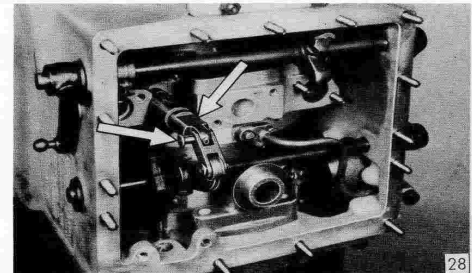

21. Place detent spring and guide pin in position and bolt detent pawl assembly to casing, replacing any spacing washers which may have been fitted between casing and pawl assembly bracket (fig. 29).

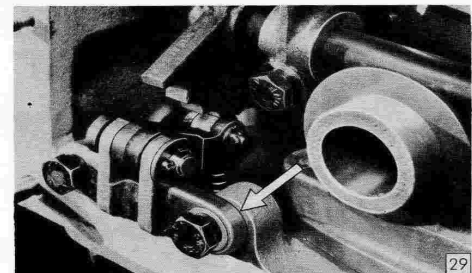

22. The kickdown and tow start valves are placed in their respective bores and checked for free movement, the spring is fitted to the tow start valve and the cap replaced with a new gasket, after tightening nuts, re-check kickdown valve for free movement (fig. 30).

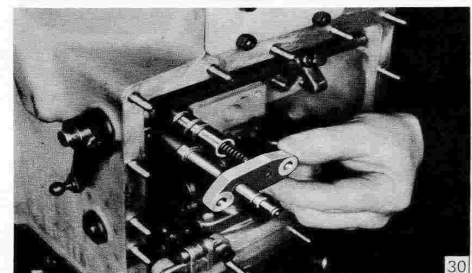

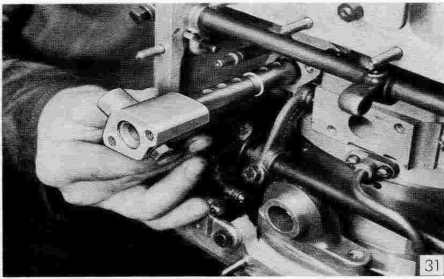

23. The governor valve, with detent housing attached, is inserted in the governor valve bore and checked for free movement (fig. 31).

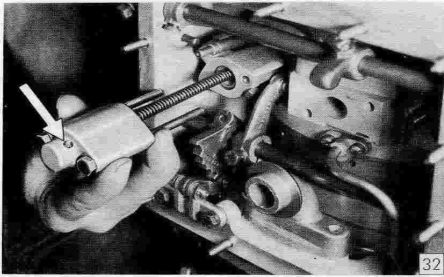

24. Two governor valve springs are fitted to the guide pin and placed in the valve cap, with the guide pin head in the cap, the valve cap is secured with two bolts, and must be fitted with the exhaust arrowed in fig. 32 towards the front of the gearbox.

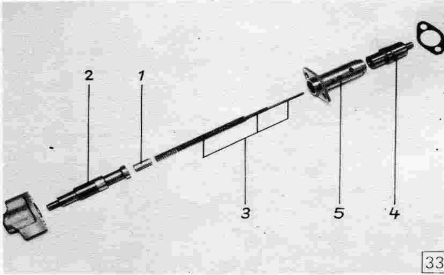

25. Clutch relief valve components (fig. 33) in order of installation.

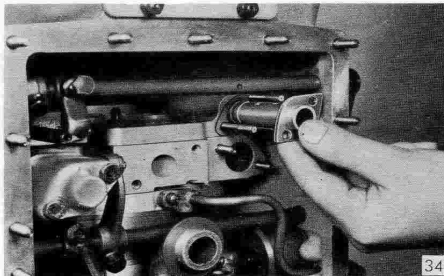

26. Fit gasket to clutch relief valve studs, the valve (fig. 33,4) is inserted in the sleeve (fig. 33,5) and both inserted in the clutch relief valve bore (fig.34).

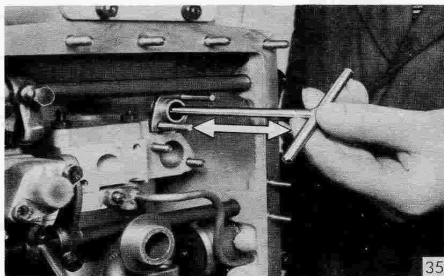

27. Screw special tool into valve and check for free movement (fig. 35).

28. The "spacer" (fig. 33,1) is inserted in the regulator (fig. 33,2) followed by the springs and guide pin (fig. 33,3), the regulator and valve cap are fitted together (fig. 36).

NOTE: The "spacer" (fig. 33,1) is fitted to units 1001 R to 1100 R only.

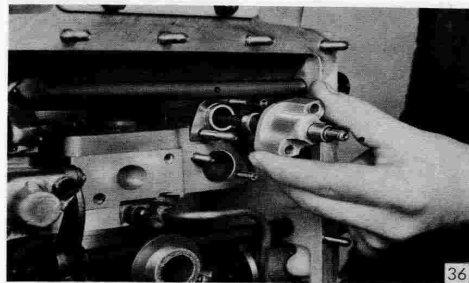

36

29. The valve cap is secured with nuts and waved washers (fig. 37), the regulator should be checked for free movement, if the regulator is not free an improvement may be obtained by turning the valve cap through 180°.

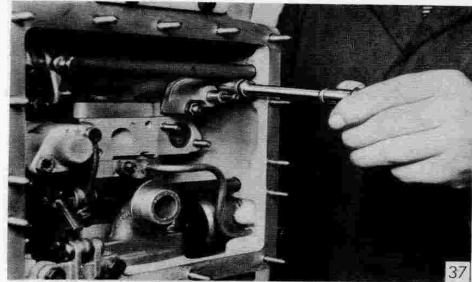

37

30. Brake relief valve components (fig. 38) in order of installation.

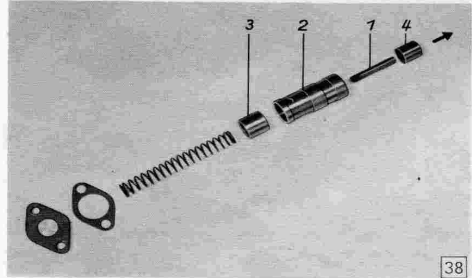

38

31. The valve (fig. 38,4) is screwed onto the special tool, placed in the working position and checked for free movement (fig. 39), the tool is then removed leaving the valve in the bore.

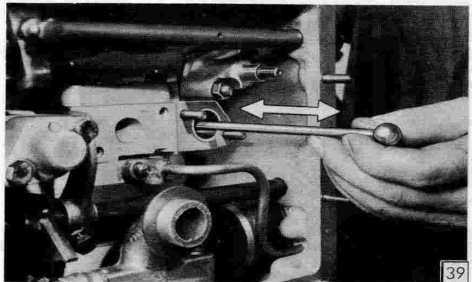

39

32. The valve pin (fig. 38,1) is placed in the small bore of the sleeve (fig. 38,2) and the sleeve inserted in the valve bore (fig. 40).

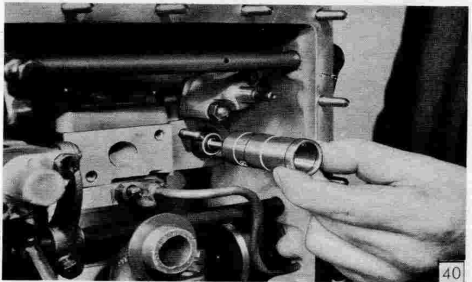

40

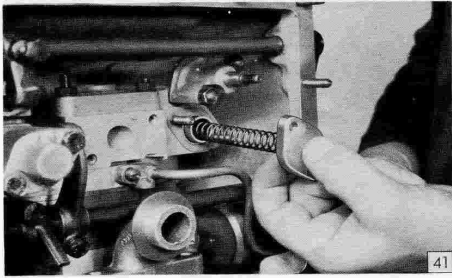

33. A new gasket is fitted over the cap retaining studs, the piston (fig. 38,3) inserted in the sleeve, open end outwards, and checked for free movement, the spring and cap are fitted (fig. 41) and secured with nuts and waved washers.

NOTE: Do not confuse the brake relief valve spring with the kickdown return spring, the brake relief valve spring has 19 coils and the kickdown spring 31 coils.

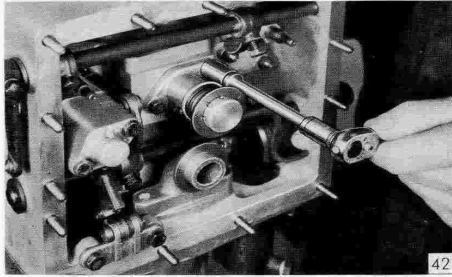

34. The front pump suction pipe is fitted with a new gasket and bolted into position (fig. 42).

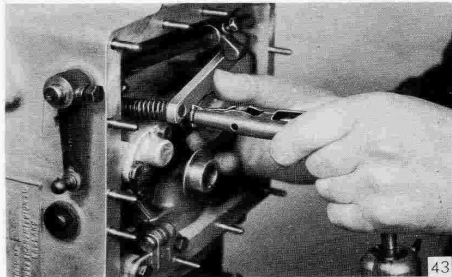

35. The kickdown return spring is placed over the kickdown valve stem and the beam fitted to the kickdown valve stem and the regulator pin, keeping the actuating cam above the beam.

Pressure on the beam will compress the kickdown spring and the "twickclips" may be fitted (fig. 43).

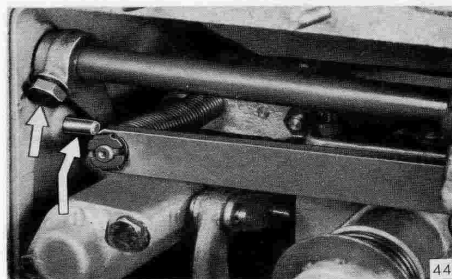

36. The beam actuating cam is positioned so that the tapered screw engages with the drilling in the shaft. Free play between the beam and the cam should not exceed about .010", this may be adjusted by altering the position of the lever arrowed in fig. 44.

37. Fit new gasket in position over sump retaining studs.

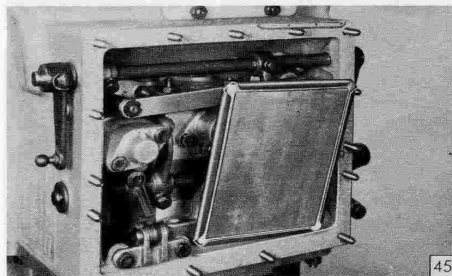

38. Place oilfilter in position (fig. 45).

39. Fit sump and sump stiffener.

Dismantling the geartrain.

1. Remove circlip retaining the rear oil pump driving gear (fig. 46).

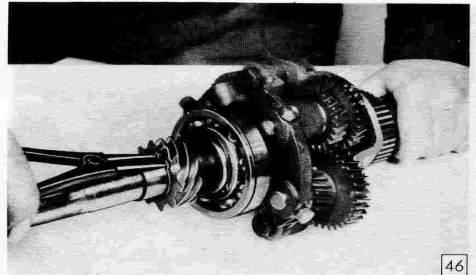

46

2. Take off gear (fig. 47) and remove key from output shaft.

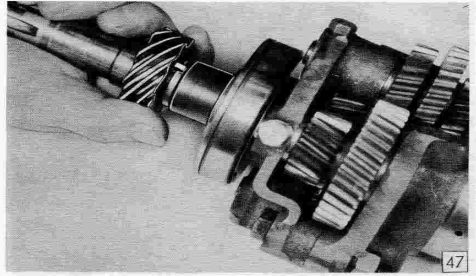

47

3. Support the gear train by the output shaft in a soft jawed vice, and undo the planet carrier securing bolts (fig. 48).

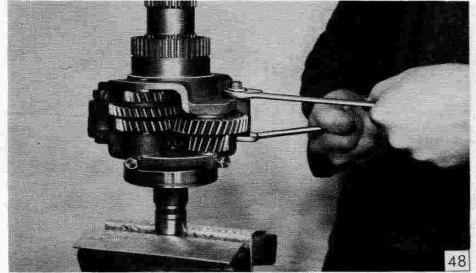

48

4. Remove the geartrain from the vice and gently tap the output shaft on a wooden block, the two halves of the cage will separate (fig. 49).

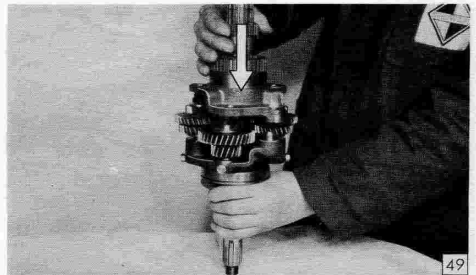

49

5. Withdraw front half of planet carrier and remove dowels if free (fig. 50). Remove input shaft, sleeve, and planetary gears.

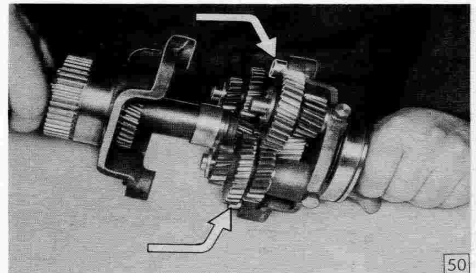

50

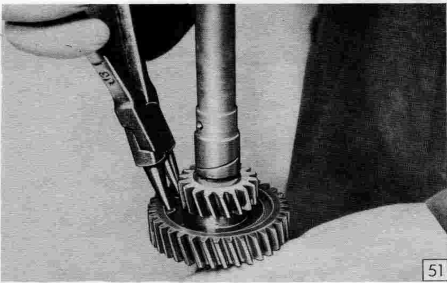

51

6. Separate input and output shafts by removing circlip indicated in fig. 51.

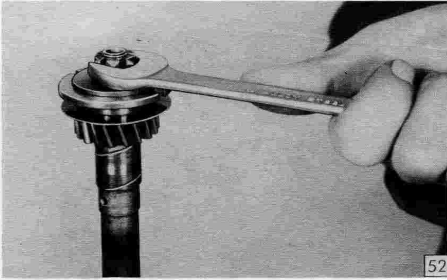

52

7. Take out split-pin securing slotted nut on input shaft and undo nut. Take off washers and bush (fig. 52).

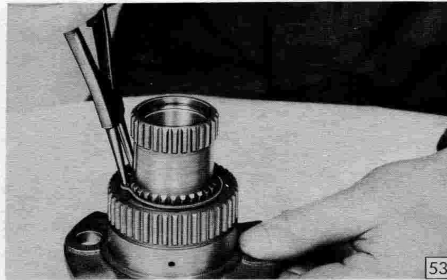

53

8. Remove reaction sleeve retaining circlip, in front half of planet carrier (fig. 53).

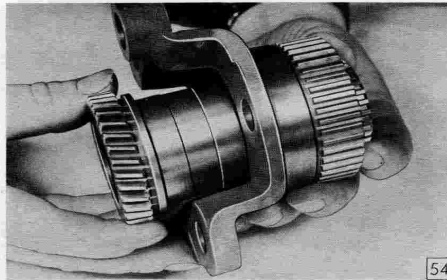

54

9. Withdraw reaction sleeve, bush, and thrust washer, and take out two thrust washers in planet carrier (fig. 54).

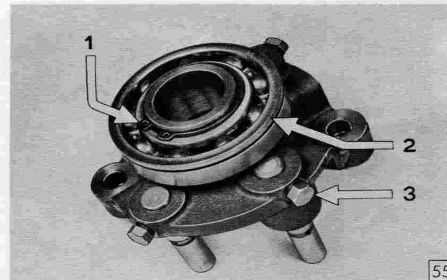

55

10. To complete the disassembly of the rear half of the planet carrier, take off the circlip (fig. 55,1), remove the bearing (fig. 55,2) and the chip guard (units 1001 R to 1046 R only).

11. Unscrew spindle retaining bolts (fig. 55,3) and remove planetary gear spindles.

Assembling the geartrain.

1. Fit planet spindles and secure with screws and spring washers. Check spindles for length, spindles marked 1 in (fig. 56) are longer than spindles marked 2.
2. Place chip guard in position (units 1001 R to 1046 R only) followed by bearing with circlip groove in outer race uppermost (fig. 57).
3. Fit circlip (fig. 55,1).
4. Replace dowels.
5. Support input shaft in soft jawed vice.
6. Place steel washer in position, followed by bronze bush with flange uppermost, fit "D" steel washer with chamfer uppermost (fig. 58).
7. Fit slotted nut and secure with split pin.
8. Support output shaft in soft jawed vice.
9. Offer input shaft sub-assembly to output shaft (fig. 59). Ensure that pins in output shaft engage with slots in flanged bush.
10. Fit circlip (fig. 60).

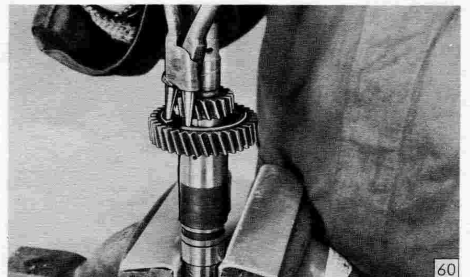
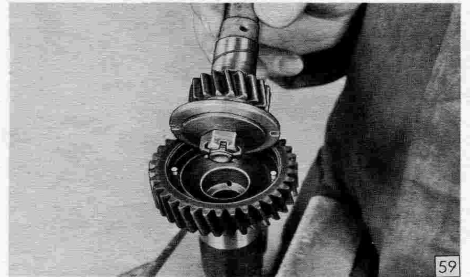
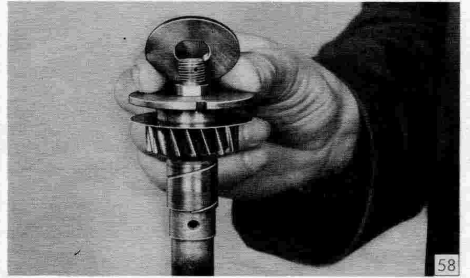
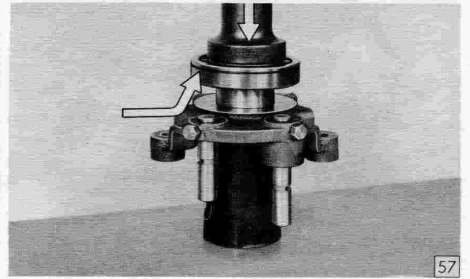
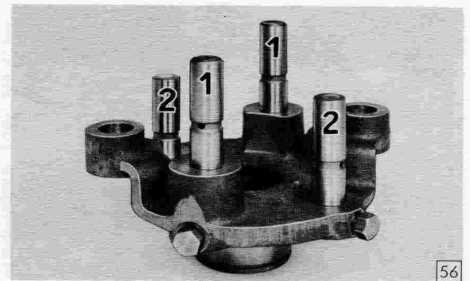

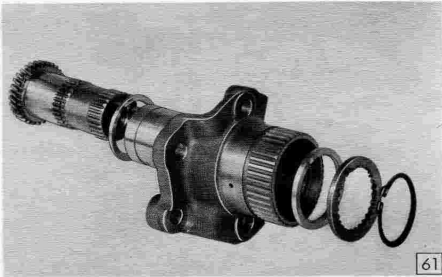

11. Assemble reaction sleeve as (fig. 61), bronze thrust washer with chamfer facing gear, followed by the bronze bush, place the reaction sleeve in the front half of the planet carrier (fig. 62), fit bronze thrust washer with chamfer uppermost, followed by splined steel washer and circlip.

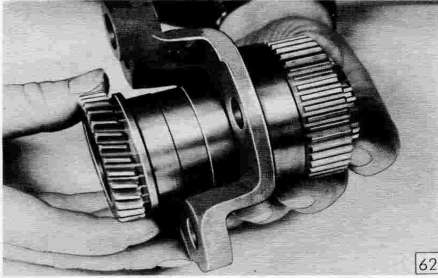

12. Support rear half of planet carrier by retaining screws of long spindles, in vice (fig. 63).

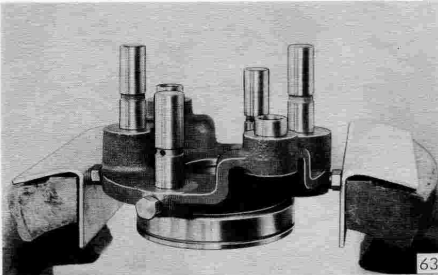

13. Place bush in position with groove uppermost in rear half of planet carrier (fig. 64).

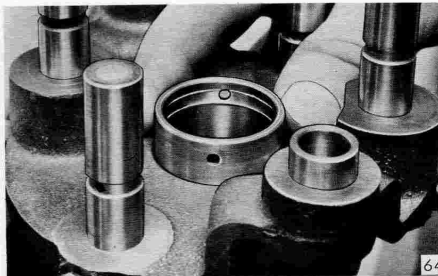

14. Fit "input and output shafts" sub assembly in rear planet carrier, output shaft downwards (fig. 65).

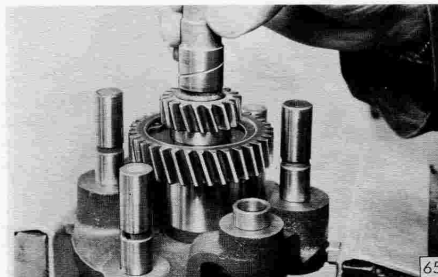

15. Thrust washers for the double pinions are fitted to the two lower laying spindles.

NOTE: Pairs of thrust washers of four different diameters are used in conjunction with the planetary gears, the correct size in each case may be determined by comparing the diameter of the washer with the ground end of the gear.

16. The two double pinions with their bushes are fitted to their spindles, at the same time, with the smaller diameter gears lowermost.

The pinions are so arranged that the locating marks and the spindles lie on a common straight line (figs. 66 and 67).

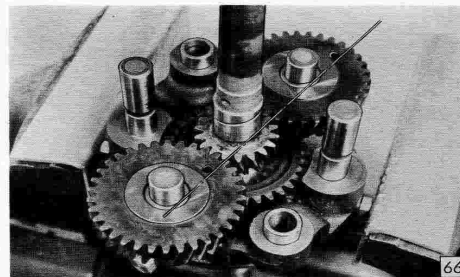

17. Select the correct thrust washers for the cluster gears and place in position, the pinions are fitted as in (fig. 68) with the locating marks uppermost.

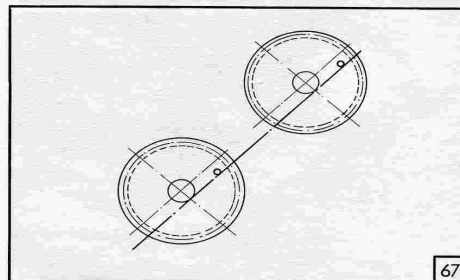

18. When the planetary pinions are fitted the pinions and locating marks should appear as in (fig. 69).

NOTE: If the pinions are incorrectly assembled it will not be possible to fit the input and reaction sleeves.

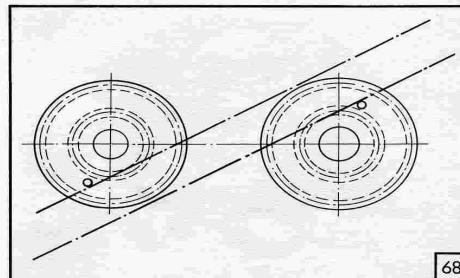

19. Select and fit the correct thrust washers to the spindles.

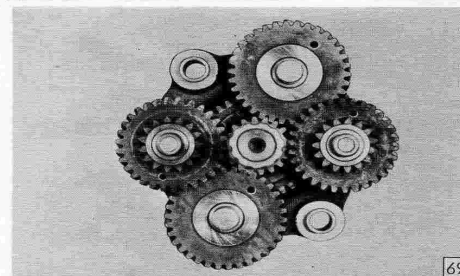

20. Fit the input sleeve and the plain bearing arrowed in (fig. 70).

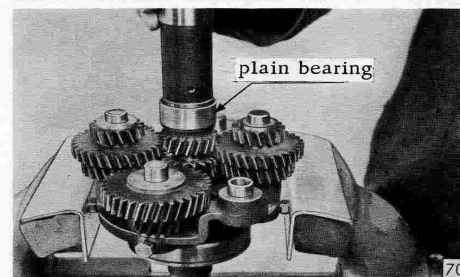

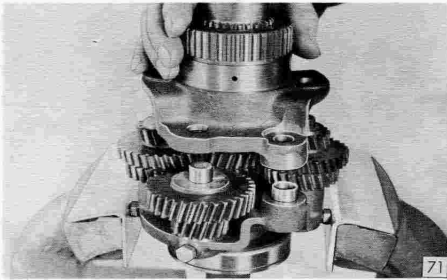

71

21. Lower the front planet carrier assembly into position (fig. 71) and secure engagement of the pinions by turning the reaction sleeve. The two halves of the planet carrier are brought together by gentle tapping with a mallet, checking frequently that the input and reaction sleeves are free to turn.

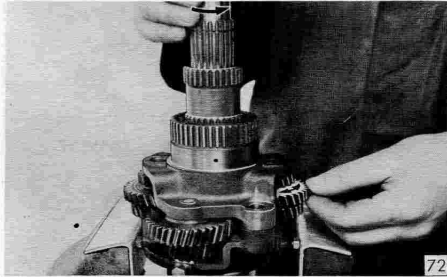

72

21. Lift and turn the input sleeve, it should turn freely, with free play at the pinions in all positions (fig. 72).

23. Fit and tighten planet carrier securing bolts.

24. Remove gear-train from vice, fit key in output shaft, fit rear pump driving gear and circlip.

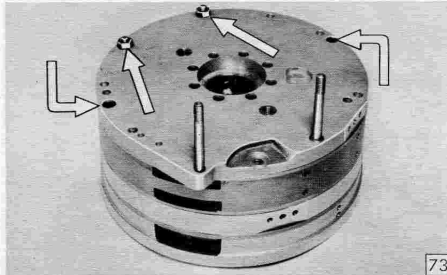

73

Dismantling the brake unit.

1. Remove allen screws and nuts arrowed in fig. 73.



74

2. Exert pressure on brake front plate to overcome push off springs and undo stud (fig. 74).

3. The brake unit may now be completely disassembled, wash all components in clean petrol and blow off with compressed air.

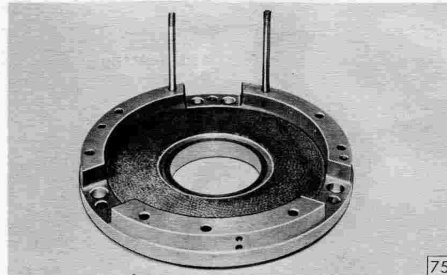

75

Assembling the brake unit.

1. Place brake back plate on clean surface (fig. 75).

2. Place plain steel brake spinner plate in position (fig.76).

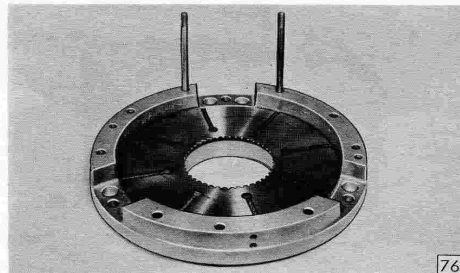

3. Fit floating pressure plate, this is a steel plate to both sides of which is bonded friction material (fig. 77).

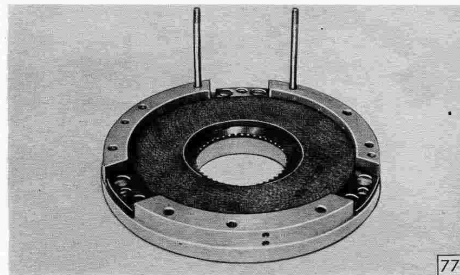

4. Place second plain steel brake spinner plate in position (fig. 78).

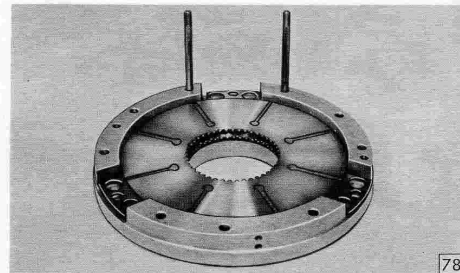

5. Fit six push off springs, and pressure plate with friction material downwards (fig. 79). The steel pressure plate for first gear brake must not be confused with the cast iron pressure plates used in the 2nd and 3rd gear brakes.

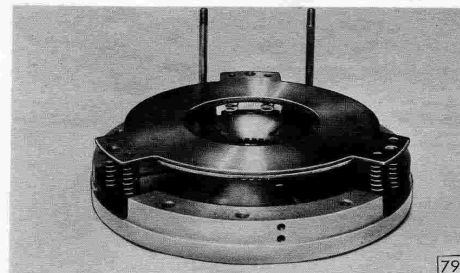

6. Place the asbestos insulator centrally on the pressure plate (fig. 80).

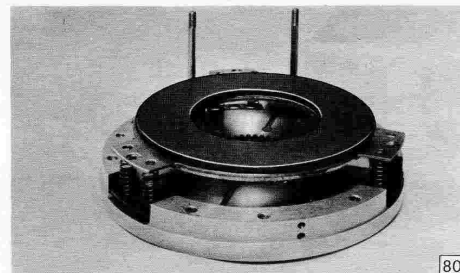

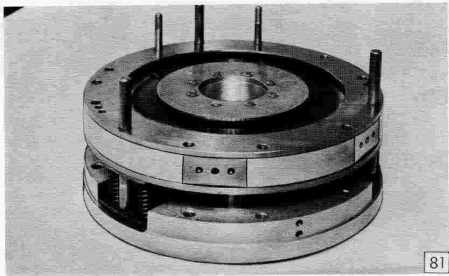

7. The diaphragm body and three dowels are fitted as in fig. 81. The two faces machined to receive the capacity cylinder pipes are opposite the two studs fitted to the brake back plate. All stud holes should be in line.

Should the outer clamp rings become detached they should be re-fitted with the chamfered inner edge nearest the diaphragm.

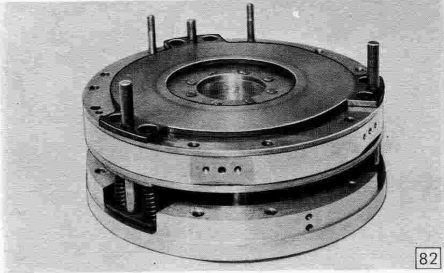

8. Place the 2nd gear pressure plate in position with the insulating material lowermost (fig. 82). The 2nd and 3rd gear plates differ in that the 2nd gear insulator area is smaller.

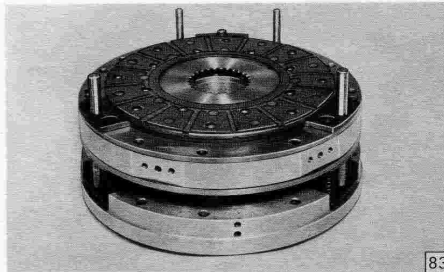

9. The 2nd gear brake spinner is placed in position (fig. 83), the splined centre of the 2nd gear brake is of greater diameter than that of the 3rd gear brake spinner.

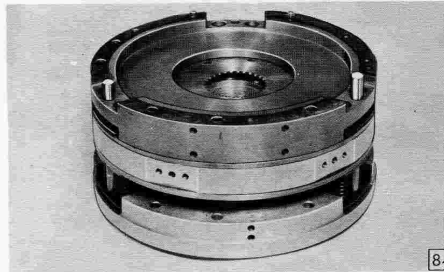

10. Fit a new gasket followed by the brake centre plate (fig. 84) ensuring that all drillings are in line and unobstructed.

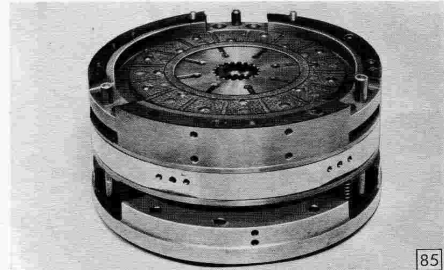

11. Fit a new gasket to the brake centre plate (fig. 84).

12. Place the 3rd gear brake spinner plate in position (fig. 85).

13. Place six push off springs in position followed by the third gear brake pressure plate, with the insulator uppermost (fig. 86).
14. Fit the brake front plate as in fig. 87 and ensure that all holes are in line.
15. Exert pressure on the brake front plate to overcome push off springs and fit retaining stud.
16. Fit allen screws, nuts and waved washers as indicated in fig. 73 and check that all springs are correctly entered in their respective pockets.

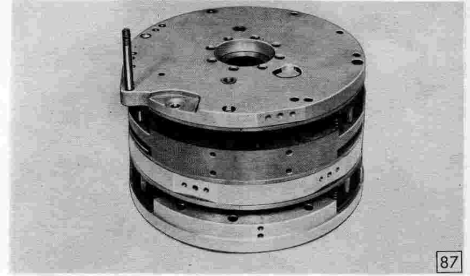
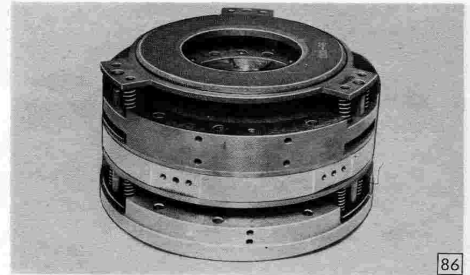

Dismantling the hydraulic unit and front pump.

When the gearbox is dismantled all valves are removed from the hydraulic unit (see page 31).



1. Remove rear pump delivery pipe and gasket (fig.88).

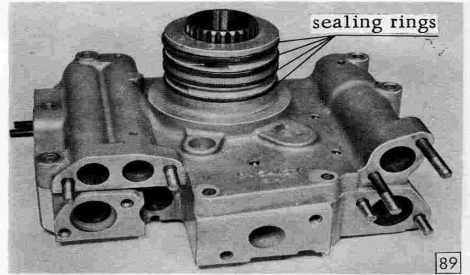

2. Unclip and remove oil sealing rings (fig. 89).

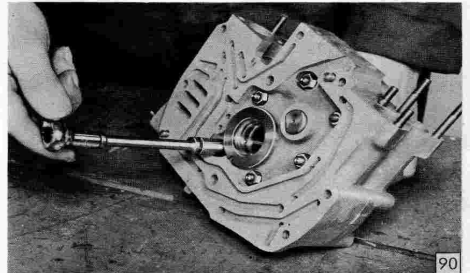

3. Unscrew nuts at rear of hydraulic unit (fig. 90).

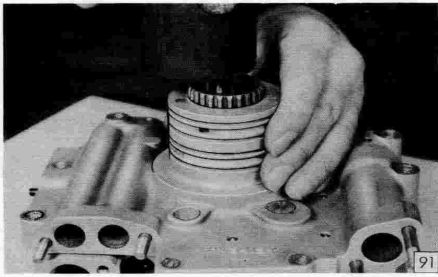

4. Hold hydraulic unit by feed member, just clear of wood surface, tap pump drive gear with a rubber mallet to part unit (fig. 91).

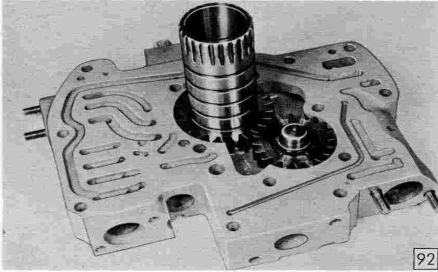

5. Take out pump gears, upper spacer and roller bearings (fig. 92).

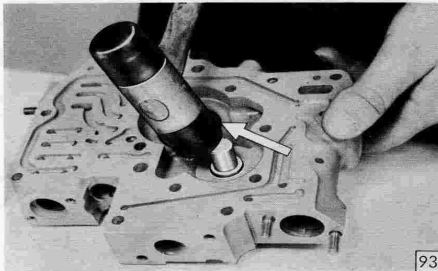

6. Remove bronze lubricating bush (arrowed) and tap out idler gear spindle with rubber mallet (fig. 93).

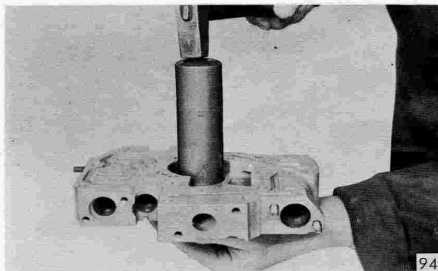

7. The thrust bearing may be removed with the aid of a suitable bar (fig. 94), the unit being held in the hand.

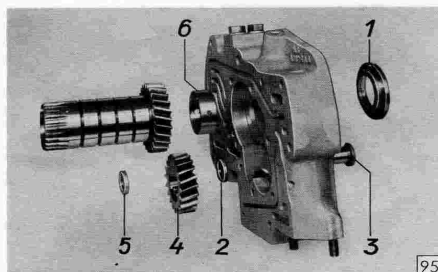

Assembling the hydraulic unit and front pump.

NOTE: The hydraulic unit faces are lapped and the slightest damage will result in leakage, the unit should be washed in clean petrol and blown off with compressed air. No material other than a clean wash leather should be used to remove finger marks etc.

1. Fig. 95 shows an exploded view of the pump body components.

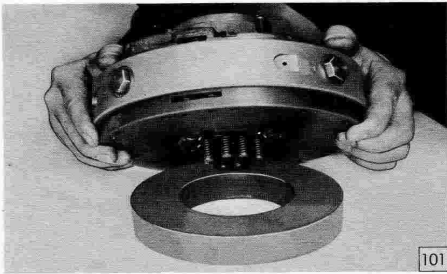

101

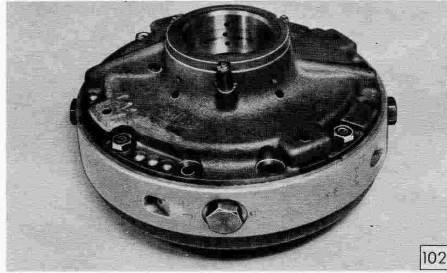

102

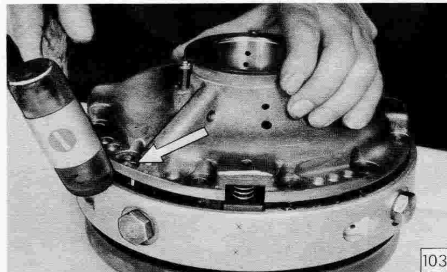

103

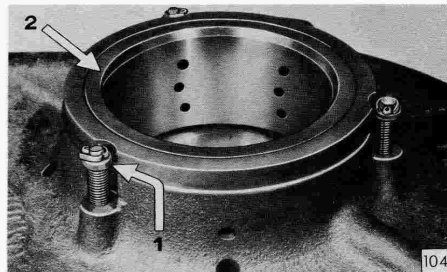

104

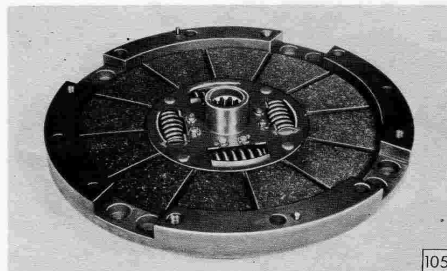

105

Dismantling the clutch.

1. Support the clutch in such a way that the damper springs are protected (fig. 101).
2. Remove four securing bolts (fig. 102).
3. Tap diaphragm body with plastic mallet to free dowels (fig. 103) and lift off clutch back plate.
4. Remainder of clutch components may now be disassembled.
5. Remove floating and trafficking valves from clutch valve bores.
6. To remove pump drive plate, disassemble retaining pins arrowed in in fig. 104,1.
7. The distribution bush (fig. 104,2) may be pressed out.
8. Clean all parts thoroughly in petrol and blow off with air pressure.

Assembling the clutch.

1. Support front plate as in (fig. 101).
2. Place "A" spinner plate, damper springs downwards in clutch front plate (fig. 105).

- Fit the eight outer and eight inner push off springs into the recesses in the front plate, arrange the pressure plate with the insulating material uppermost so that the springs enter the recesses and the "X" locating marks arrowed in fig. 106 are in line.

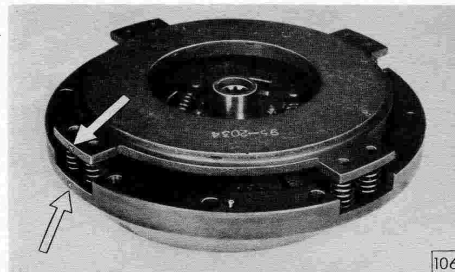

- The trafficking and floating valves are thoroughly cleaned in petrol, fitted in their respective bores and checked for free movement (see also Borgward publication PKW 1/32-37/4 page 13).

The valve bores may be identified by letters stamped near the bores on the clutch diaphragm body.

- A.T. - Trafficking valve "A" clutch
- B.T. - Trafficking valve "B" clutch
- A.F. - Floating valve "A" clutch
- B.F. - Floating valve "B" clutch

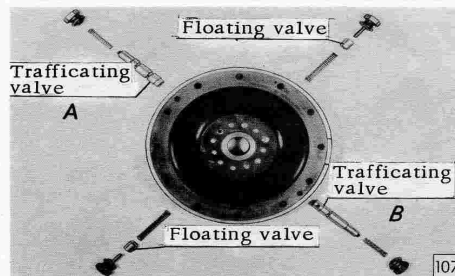

- Should the outer clamp rings be free, they are replaced with all holes in line and the chamfered inner edge of the rings nearest the diaphragm. A gasket is fitted between each clamp ring and the valve body (fig. 108).

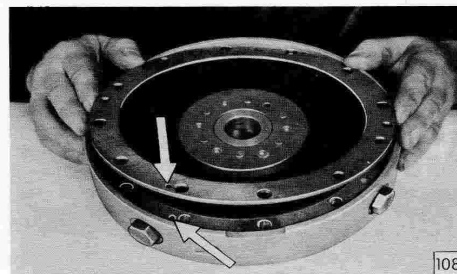

- Place the valve body in position with the "X" locating marks in line (fig. 109).

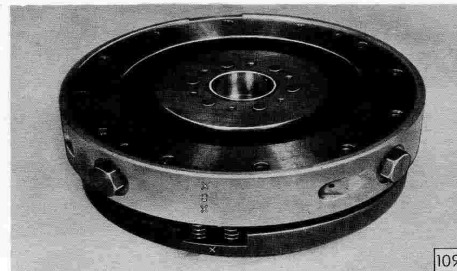

- Fit the "B" pressure plate with the insulating material lowermost and the locating marks in line as arrowed in fig. 110.

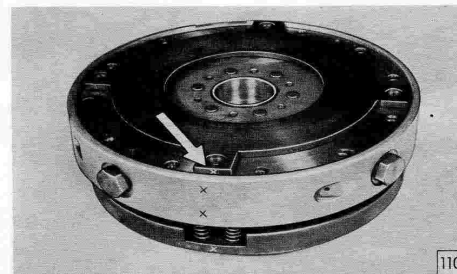

- Lightly oil the bronze bush.

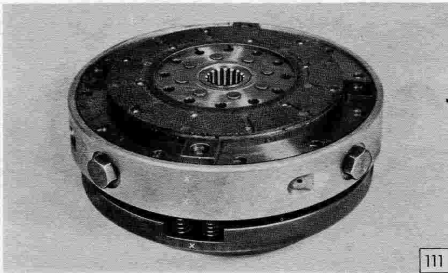

111

9. Fit the "B" spinner plate as in fig. 111.)

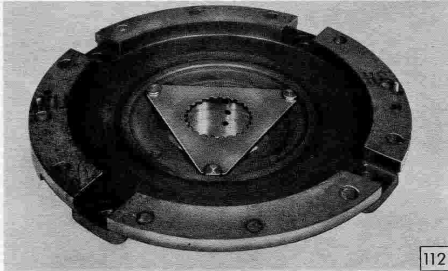

112

10. Press in distributor bush with chamfer uppermost (see fig. 104).

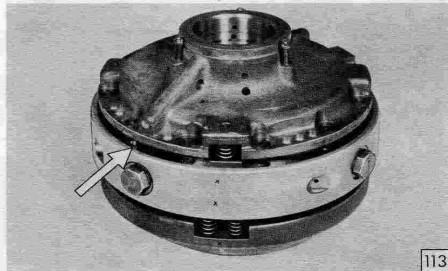

113

11. The pump drive plate is fitted and secured (fig. 104).

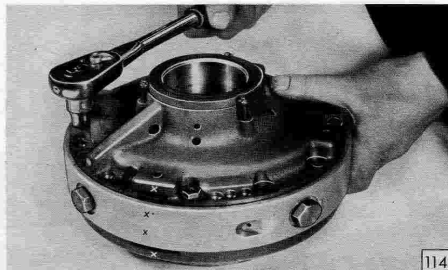

114

12. Fit new gasket to outer clamp ring and place four single springs in the recesses in the "B" pressure plate, position clutch front plate as in (fig. 113) check that dowels locate correctly and that "X" locating marks line up.

13. Secure clutch with four bolts and spring washers, check that pressure plate ears are correctly positioned in front and back plates, and that all springs are properly entered in spring recesses.

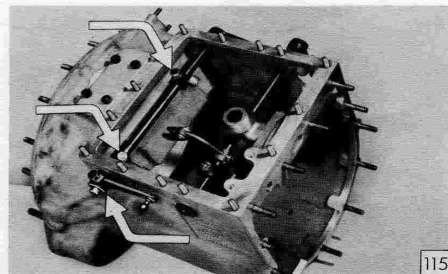

115

Dismantling the front case sub-assembly.

1. Loosen bolts securing regulator cam and stop lever on control shaft (fig. 115).
2. Remove lever fitted to outside of casing (fig. 115).

3. Smooth off screw location drillings as arrowed in fig. 116 with file, to prevent damaging casing when removing shaft.
3. Remove shaft.
5. To take out selector shaft, remove circlip and washer on outside of casing.
6. Unscrew pinch bolts on quadrant and selector lever.
7. Remove quadrant and selector lever keys from shaft.
8. Remove shaft.
9. The rear suction pipe (fig. 117) is withdrawn. Together with studs and gasket, if the selector shaft is in position the rear suction pipe may be removed by first unscrewing studs.

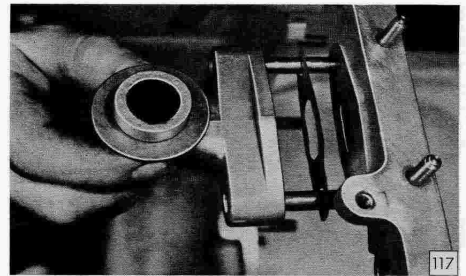
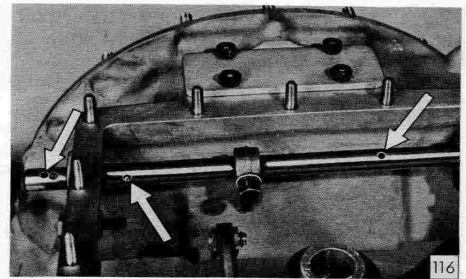

Assembling front case.

1. Place rear pump suction pipe in position with new gasket.
2. Fit two new "O" rings in lever end of selector shaft (fig. 119,2).
3. Insert shaft in first casing bore.
4. Slide selector lever and quadrant on shaft, the quadrant boss is on the side remote from the selector lever (fig. 118).
5. Fit keys.
6. Position new "O" rings in grooves on other end of shaft (fig. 119,1).
7. Pass shaft through casing and secure with washer and circlip.
8. Position selector lever and quadrant on keys and secure with pinch bolts, fig. 118 shows relative positions of levers.
9. Fit two new "O" rings to regulator shaft and pass through casing bore (fig. 120,2).

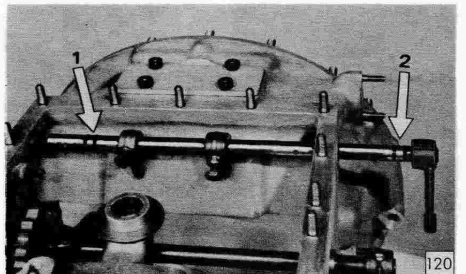
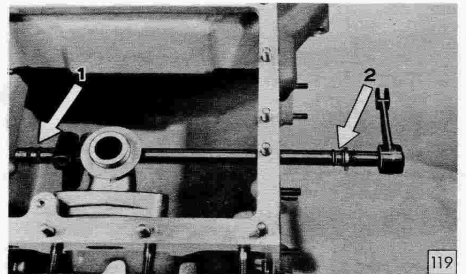
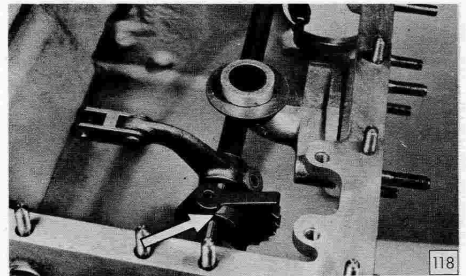

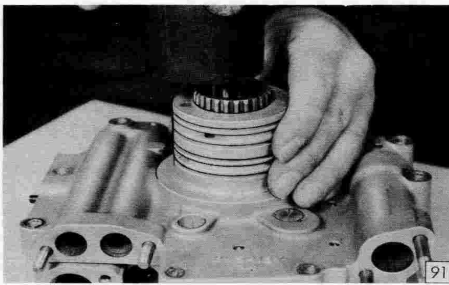

4. Hold hydraulic unit by feed member, just clear of wood surface, tap pump drive gear with a rubber mallet to part unit (fig. 91).

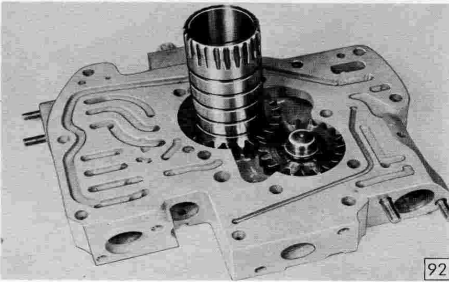

5. Take out pump gears, upper spacer and roller bearings (fig. 92).

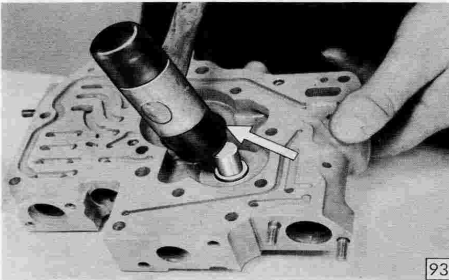

6. Remove bronze lubricating bush (arrowed) and tap out idler gear spindle with rubber mallet (fig. 93).

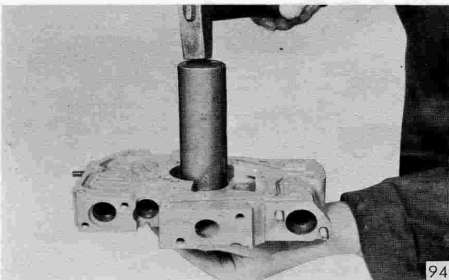

7. The thrust bearing may be removed with the aid of a suitable bar (fig. 94), the unit being held in the hand.

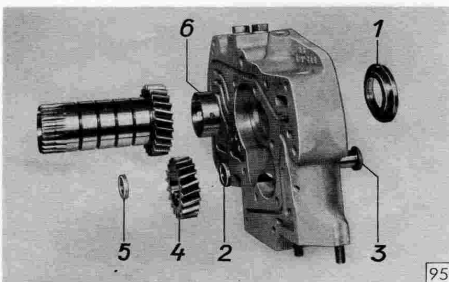

Assembling the hydraulic unit and front pump.

NOTE: The hydraulic unit faces are lapped and the slightest damage will result in leakage, the unit should be washed in clean petrol and blown off with compressed air. No material other than a clean wash leather should be used to remove finger marks etc.

1. Fig. 95 shows an exploded view of the pump body components.

10. Slide regulator cam and stop lever on to shaft, fit remaining two "O" rings and pass shaft through casing (fig. 120,1).
11. Fit and secure outside lever.
12. Move regulator cam into position so that tapered screw engages drilling in shaft.
13. Postpone securing stop lever until beam is in position, and adjust as in (fig. 44) paragraph 36 "Assembling the gearbox".

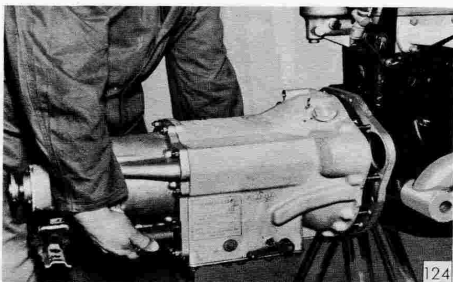
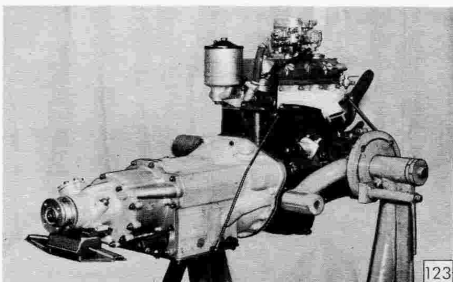
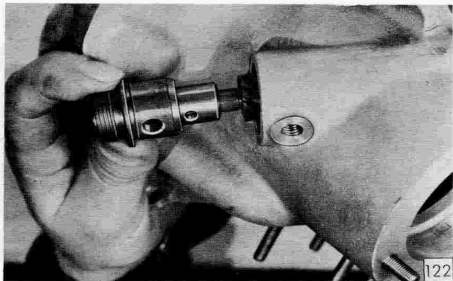
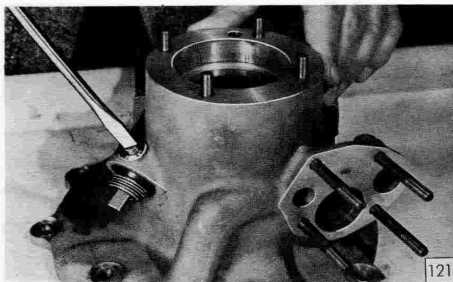

Removal and fitting of the speedometer driving gear.

1. Remove retaining screw (fig. 121).
2. Withdraw gear from rear case.
3. When replacing ensure that locating hole coincides with tapped hole in rear case (fig. 122).

Dismounting gearbox and clutch from engine.

1. Before removing engine from vehicle, drain gearbox oil and remove oil filler pipe.
2. Secure engine in assembly stand (fig. 123).
3. Disconnect regulator rod at gearbox lever.
4. Remove starter motor.
5. Undo nuts securing gearbox to mounting plate.
6. Remove gearbox (fig. 124).

NOTE: Gearbox must be supported when nuts are removed and withdrawn with care to prevent damaging hydraulic unit.

7. Undo eight bolts and spring washers securing clutch to flywheel (fig. 125), the four marked bolts are left in position.
8. A lever used between the valve body and flywheel will loosen clutch if necessary.

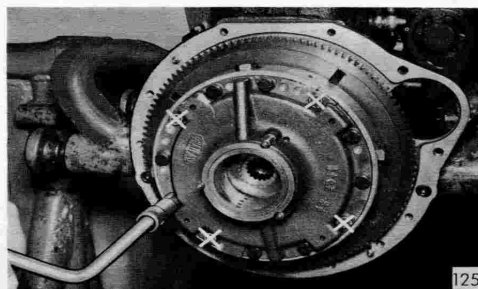

Mounting the clutch and gearbox on the engine.

1. Draw the clutch into the flywheel by tightening securing bolts evenly.
2. A new gasket is fitted, and the oil sealing rings checked to ensure they are properly "latched", the gearbox is offered to the clutch whilst being kept absolutely square to the mounting plate (fig. 126) to avoid damaging the sealing rings. The engine is turned to aid engagement of the input shaft and sleeve in the clutch splines. The gearbox should move easily into position, if resistance is felt, withdraw gearbox and re-examine sealing rings.
3. Secure gearbox to mounting plate with nuts and spring washers.
4. Fit gasket and starter motor.
5. Fit regulator rod and adjust (see KD Bulletin PKW 1/32-37/4).
6. When the engine is installed, the filler pipe and new gasket are fitted and oil added.

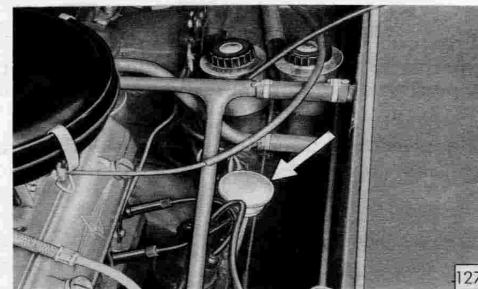
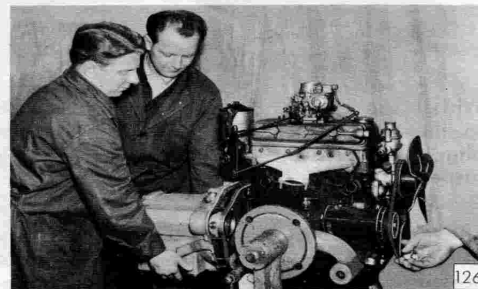

Oil requirement	5 1/2 imp. pints
	6 3/4 US. Liq.pints (3,2 l)

The following oils only are recommended, and may be mixed without harmful result.

- Castrol TQ
- Caltex 3528 Texamatic Fluid
- Esso ATF 55
- Mobil Fluid 200 y
- Shell Donax T 6
- BV-ÖI SGF

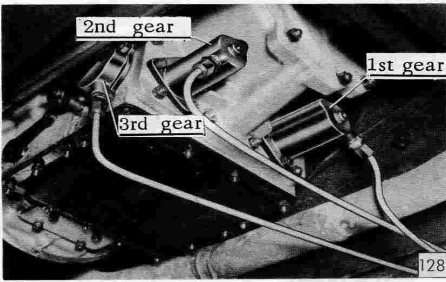

Checking capacity cylinder pressures.

If it is necessary to check capacity cylinder pressures as an aid to fault finding, see fault finding chart in KD Bulletin PKW 1/32-37/4, connect a pressure gauge to the capacity cylinder as in fig. 128 (the capacity cylinder is tapped 1/8th B.S.P.).

The first gear capacity cylinder maintains pressure in the first gear brake diaphragm whilst the second gear brake is taking up, the second gear capacity cylinder maintains pressure in the second gear brake diaphragm, whilst the third gear brake is taking up. The third gear capacity cylinder performs a similar function whilst the "B" clutch is taking up.

Whilst the gear change is taking place pressure is directed away from one brake (and capacity cylinder) to the next brake (and capacity cylinder). To check a particular brake circuit it is only necessary to check the pressure of the capacity cylinder which is connected to that particular brake, which is suspected of being faulty.

The pressure may be checked with the vehicle stationary or by road testing, in the first case the rear wheels must be jacked clear of the ground, and it is advisable to remove the rear road wheels, the pressure gauges may be mounted outside the vehicle.

If a road test is decided upon pipes leading from the capacity cylinders to pressure gauges, must be long enough to bring gauges inside vehicle (fig. 129) preferably on the passenger side, the pipes from the capacity cylinders must be secured to maintain ground clearance.

The pressures should approximate those shown in the following table, if pressures are low action should be taken in accordance with the instructions in Borgward-Publication-Bulletin PKW 1/32-37/4.

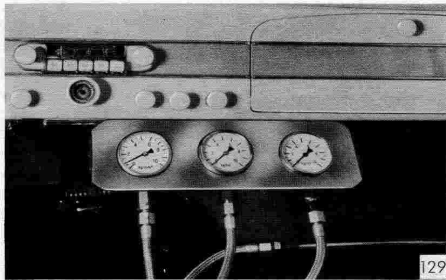

Accelerator Pedal position	1st Gear	2nd Gear	3rd Gear
Pedal released	36 lb/sq. ins	36 lb/sq. ins	22 lb/sq. ins
Kickdown	115 "	115 "	66 "

To check first gear idling pressure move selector lever into the first gear position. To check second or third gear idling pressure, select the required gear, speed up the engine until the required gear is obtained, release the throttle pedal and read the pressure gauge.

To check kickdown pressures, move the selector lever into the appropriate position.

- To check first gear pressure - select first gear
- To check second gear pressure - select second gear
- To check third gear pressure - select third gear

With the accelerator pedal in the kickdown position speed up the engine until the required gear is obtained, and read the pressure gauge without releasing the accelerator pedal.

Exploded view of hydraulic unit.

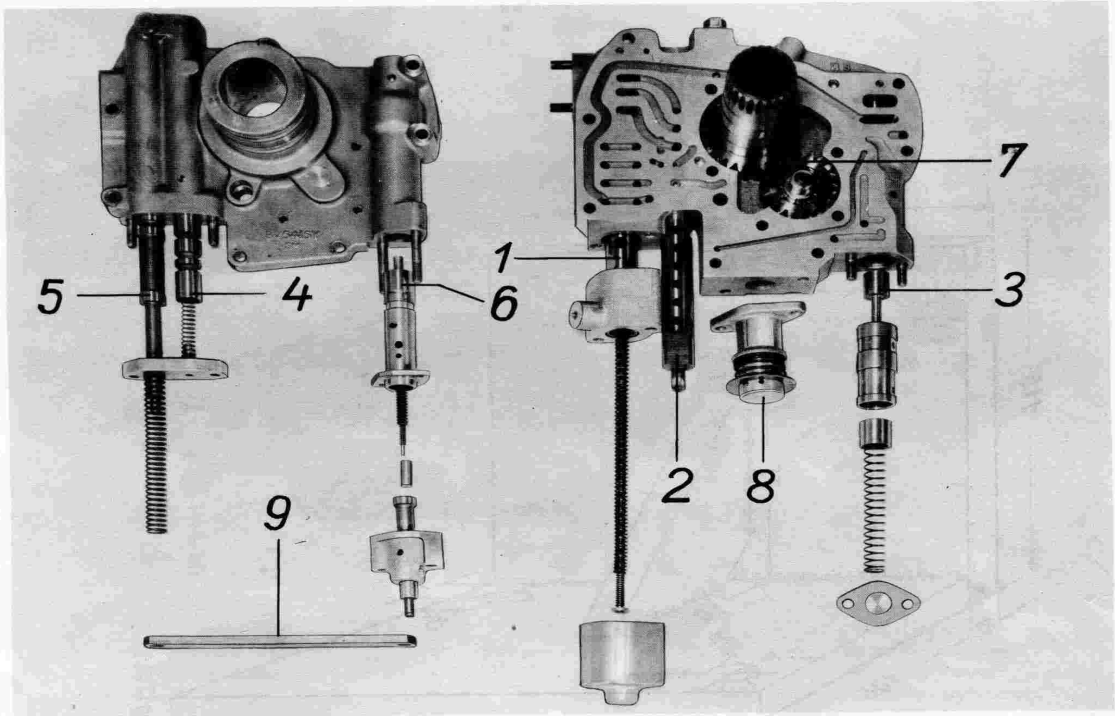

- | | |
|------------------------|-------------------------|
| 1. Governor valve. | 6. Clutch relief valve. |
| 2. Selector valve. | 7. Oil pump gears. |
| 3. Brake relief valve. | 8. Pump suction pipe. |
| 4. Tow start valve. | 9. Cross beam. |
| 5. Kickdown valve. | |

I. BORGWARD Special tools

1. Output flange spanner (WK 112)
2. Output flange drawer (WK 56)
3. WK 160 tools consists of
 - Threaded rod for clutch relief valve (WK 160 a)
 - Threaded rod for trafficking valve (WK 160 b)
 - Threaded rod for brake relief valve (WK 160 c)
 - Twickclip pliers (WK 160 d)

II. Useful tools and measuring instruments

1. Feeler gauges
2. Straight edge

